

Terrco[®], Inc.

01-S SERIES



OPERATING INSTRUCTIONS MAINTENANCE INSTRUCTIONS ILLUSTRATED PARTS LIST

Terrco[®] Inc.

222 1st Avenue NW • Watertown, SD 57201

Phone: (605) 882-3888 • Fax: (605) 882-0778

Website: www.terrco.com • Email: info@terrco.com

Terrco[®] 01-S SERIES

HP/KW	7.5-5.6
SWEEP OF DISCS	27" (685.8 mm)
ABRASIVE PRESSURE	440 lbs (200 kg)
WIDTH OF MACHINE	28" (711 mm)
LENGTH OF MACHINE HANDLE UP	29-1/4" (743 mm)
LENGTH OF MACHINE HANDLE DOWN	56-1/2" (1435 mm)
HEIGHT OF MACHINE	54" (1371 mm)
NET WEIGHT	775 lbs (352 kg)
SHIPPING WEIGHT	860 lbs (390 kg)
WATER TANK	7 gallons (26.5 l)
POWER CORD (8-3)	100 ft (30.5 m)

* WEIGHT MEASURED WITH FOUR POCKET WEIGHTS

- Optimal for jobs under 5,000 sq. ft.
- Stainless Steel Guards
- Stainless Steel Water Tanks
- Wet/Dry Setup
- Variable Speed or Magnetic Start
- Direct Drive, No Belts
- Leveling System
- Adjustable Handle
- Uses Plug Stone Shape, Bolt on to Universal Tool Plate, or Speed Shift System

PRODUCTION RATES

- Mastic removal rate of 350 sq. ft. per hour
- Thin-set removal rates of 400 sq. ft. per hour
- Thin-Mil coatings removal rates of 200 sq. ft. per hour.
- Concrete polishing rates of 450 sq. ft. per hour (depending of grit)
- Rough Terrazzo rate of 600 sq. ft. per day

ELECTRICAL OPTIONS

VOLTAGE	230	230	230	230	460
PHASE	1	1	3	3	3
DRIVE	MANUAL	VARIABLE	MANUAL	VARIABLE	VARIABLE
AMP DRAW	34	34	22	22	11
BREAKER (AMPS)	50	50	30	30	30
STONE HOLDER RPM	390	390-585	390	390-585	390-585

Terrco[®] Inc.

222 1st Avenue NW • Watertown, SD 57201

Phone: (605) 882-3888 • Fax: (605) 882-0778

Website: www.terrco.com • Email: info@terrco.com

SAFETY PRECAUTIONS

This machine is intended for commercial use.

It is designed exclusively to grind and polish Terrazzo and concrete floors.

Use only recommended accessories and abrasives.

When the machine is in need of repair, use only Terrco approved parts.

All operators must read, understand and practice the following safety precautions.



WARNING: Rotating grinding wheels can cause injury, keep hands and loose clothing clear.



WARNING: Disconnect power at the machine before servicing or changing grinding stones.



WARNING: Always check ground (earth) connection prior to operating machine.

FOR SAFETY:

- Have electrician hook up power to machine.
- Always operate machine with ground fault protection.
- Eye, hearing and respiratory protection advised.
- Service and adjust guards for maximum protection. Never remove the guards.
- Keep machine clean and properly serviced.

SAFETY LABEL

The safety label is located on the drive box of the machine.
Replace label if it is damaged or illegible.

 WARNING  FOR SAFETY, READ OWNERS MANUAL BEFORE USING MACHINE	
	ROTATING CUTTERS KEEP GUARDS IN PLACE AND ADJUSTED KEEP HANDS AND FEET AWAY WHEN OPERATING
	WEAR EYE AND HEARING PROTECTION WHILE OPERATING THE MACHINE
	GRINDING CAN GENERATE DUST DUST MAY AFFECT BREATHING AVOID DUST CONTACT BY USE OF MASK OR RESPIRATOR
	DISCONNECT POWER BEFORE CHANGING TOOLING OR SERVICING THE MACHINE ALWAYS CHECK GROUND (EARTH) PRIOR TO OPERATING MACHINE



OPERATING AND MAINTENANCE INSTRUCTIONS

01-S Series



INTRODUCTION

This Manual has been prepared to assist you in the proper maintenance and operation of your Terrco® Machine. Please bear in mind that your 501-S or 701-S machine is a precise piece of machinery manufactured to exacting standards. In order for you to obtain maximum use of your machine, we suggest that you read this manual completely and thoroughly before attempting to operate your machine. A parts diagram and parts list are included to assist you in ordering the proper parts. Always give the machine number and model number when ordering your repair parts.

PRELIMINARY PROCEDURES TO FOLLOW BEFORE OPERATING MACHINE FOR THE FIRST TIME:

DELIVERY OF MACHINE

1. On delivery the contractor should very carefully examine the shipping crate to see that it has not been mishandled. Before accepting the shipment, uncrate the machine and very carefully examine the machine to ensure that nothing has been damaged. If damage is noted, request an inspection immediately and request a copy of the claim report. When accepting the machine from the delivery carrier, note the damage on the bill of lading before signing.
2. Terrco® **WILL NOT** honor any claims for broken, damaged, or missing parts that may have occurred in shipping, as each machine is checked and inspected before leaving our plant.

The machine has been fully lubricated at the factory before shipping.

ON-THE-JOB INSTRUCTIONS

INSTALLATION INSTRUCTIONS-STONES

1. Remove the weights and raise adjustable handle as far forward as possible, lock into position and put one foot on the rubber-tired wheel.
2. Tip the machine back to the floor so that the handle lays on the floor.
3. Clean stone mounting surface.
4. **IMPORTANT!** Install the plug stones in the following manner. Place the stone firmly into the plug stone holder and twist.
5. After the stones are installed raise the machine until it is in operating position with all stones on the floor. Lower handle to position best suited for the operator, and replace the removable weights.
6. **CAUTION!** NEVER ATTEMPT TO START THE MACHINE WHILE LOWERING TO THE FLOOR, as the rear stones will strike on the corners resulting in thrown stones and possible damage to the machine.

ELECTRICAL AND PLUG-IN INSTRUCTIONS

1. General Instructions

- Always operate your machine with ground faults wired at the electrical source.
- Low voltage is a common occurrence on many terrazzo jobs, and hence it is necessary that the terrazzo contractor know his incoming voltage and amperage at the machine.
- As a result of the low voltage and the use of a 230 Volt motor, Terrco® has installed a booster box with pre-wired plugs already connected to your machine.
- If the machine is to operate on an area more than 100 feet from the electrical source it will be necessary to use the next lower number (larger) size cable from the source to the 100 foot wire cable that we furnished with the machine.
- If additional cable is necessary, be sure all connections are of the proper size and that they are tight.
- As a final step before starting the machine, we strongly recommend that a voltage reading is taken; this requires very little time and could save a great deal of trouble.

GENERAL MAINTENANCE AND REPAIR INSTRUCTIONS

THE LUBRICATION OF THE MACHINE

1. The lubrication of the main gear case.
 - The main gear case contains 6-1/4 pounds of Mobilith AW-1 grease.
 - Gear case level should be checked once a year. The level of the grease in the gear case should be up to half the thickness so the helical gears (Ref. number 13 and 35 on the parts diagram).
2. The lubrication of the wheel bearings.
 - Use grease gun and grease each wheel with 1 shot of grease monthly (Ref. number 14 on the Suspension Assembly) with Mobilith AW-1 or equivalent.
3. Location of other Grease Fittings
 - Two fittings on bearing caps on top of gear case (Ref. number 7). Lubricate these fittings with Mobilith AW-1 every month with 2 shots of grease.
 - One fitting on foot leveling device (Ref. number 86); recommended grease Mobilith AW-1 or equivalent every six months with 1/2 shot of grease or as needed.
 - There are four shoulder bolts located at the pivot points of the handle bar that require 1/2 shot of Mobilith AW-1 or equivalent every six months or as needed.

KEEPING MACHINE CLEAN

1. Schedule daily cleaning after each days grinding.
 - Tilt machine back on handle.
 - Clean under carriage with water using a garden hose and nozzle.
 - Clean all grease fittings.
2. Do not let any cake-up of cement grinding paste occur as this could create an overload on your machine.
3. Avoid direct spraying of drives/ starter boxes if using a pressure washer to clean the machine.

REPLACEMENTS OF WORN, DAMAGED, OR MISSING PARTS

1. Advantages
 - If worn parts (bearings, gears, etc) are not replaced promptly, serious damage to your machine could occur.
 - Your machine will operate more efficiently with new Terrco® parts.
2. Use only authorized Terrco® parts as our warranty will not apply if other than factory authorized Terrco® parts are used.

MORFLEX FLEXIBLE COUPLINGS

1. Bolts, (Ref. number 87) should be checked weekly for tightness. Loose bolts cause extreme vibrations and premature failure of rubber inserts in the couplings.
2. Your flexible couplings (Ref. number 37) should be changed a minimum of once a year whether you use your machine or not.

HIGH MOTOR TEMPERATURE

1. Introduction
 - "Running Hot" is normal for the smaller, lighter "t" type motor.
 - Even though they will run hotter, the "T" motors run more efficiently.
 - Skin cannot withstand a temperature over 135° F yet, most electric motors on Terrco® machines are designed to operate efficiently at 165°.
2. Operating Characteristics
 - The temperatures of motors are rated by temperature rise and full load over and above room temperature (25°C or 77°F).
 - To convert degree Centigrade to degree Fahrenheit, multiply degree Centigrade by the fraction 9/5 and add 32.
 - Older (repulsive-induction) type motors were rated 40° Centigrade rise, or approximately 150° Fahrenheit.

3. Conclusion

- It is recommended that you keep your hands off the motors when they are hot.
- If you desire to know the temperature of the motor do the following:
 1. Place a 200°F thermometer on the frame of the motor.
 2. Place a glob of putty over the bulb of the thermometer.
 3. Take the temperature readings.
- Also, do not forget we use a thermal protected starters on Terrco® machines, and this protects the motor against low voltage and overload conditions which might raise the temperature of the motor beyond safe limits.

STONE WEAR AND REPLACEMENT

1. Check your stones for wear periodically, as the stones may be worn flush with stone holder plugs and the operator may be grinding with steel stone spiders.

EXCLUSIVE FEATURES OF THE 01-S SERIES

ADVANTAGES OF “T” TYPE MOTOR

1. Less amperage draw.
 - 15% less in the 5 HP size.
 - 9-1/2% less in the 7-1/2 HP size.
2. Higher safe operating temperature (165°F)
3. Lightweight.
 - 42-1/2% less in the 5 HP size.
 - 34-1/2% less in the 7-1/2 HP size.
4. Less maintenance.
 - No brushes.
 - Less internal wiring.

DESIGN ADVANTAGES OF NEW MANUAL FOOT LEVELING DEVICE

1. Improved machine control.
2. Faster and greater range of adjustments.
 - Six leveling adjustments.
 - 1/8” increments
3. Simple to operate by merely pushing down on foot lever and raising up on handle.

ADVANTAGE OF LIGHTWEIGHT MACHINE

1. Ease of transportation
2. Still has sufficient abrasive pressure by use of the removable weights.

TEN POSITION HANDLE

1. Advantages.
 - Easier to “break” machine when changing stones.
 1. After removing the weights, unscrew safety knob (Ref. number 107), push knob (Ref. number 18) to the rear to release the locking mechanism. Raise handle two or three notches, lock handle by reversing the above procedure and tilt stone holders off the floor.
 2. Pushing the handle forward two or three notches creates a safe stone position for changing, as the machine will not have a tendency to “flip-up”. It also makes it much easier to get at the stone changing area.
2. Operation
 - The adjustable handle is very easy to operate. You merely unscrew the safety knob (Ref. number 107), push knob (Ref. number 18) to the rear to release the locking mechanism. When you have raised or lowered the handle to your desired position, push knob (Ref. number 18) forward as far as you can and screw the safety knob (Ref. number 107) tight. This will lock the handle in position.
 - Make sure that you have pulled knob (Ref. number 18) completely to the rear to assure full unlocking of mechanism and the safety knob (Ref. number 107), is screwed up tight.



01-S PARTS LIST (GEAR CASE ASSEMBLY)

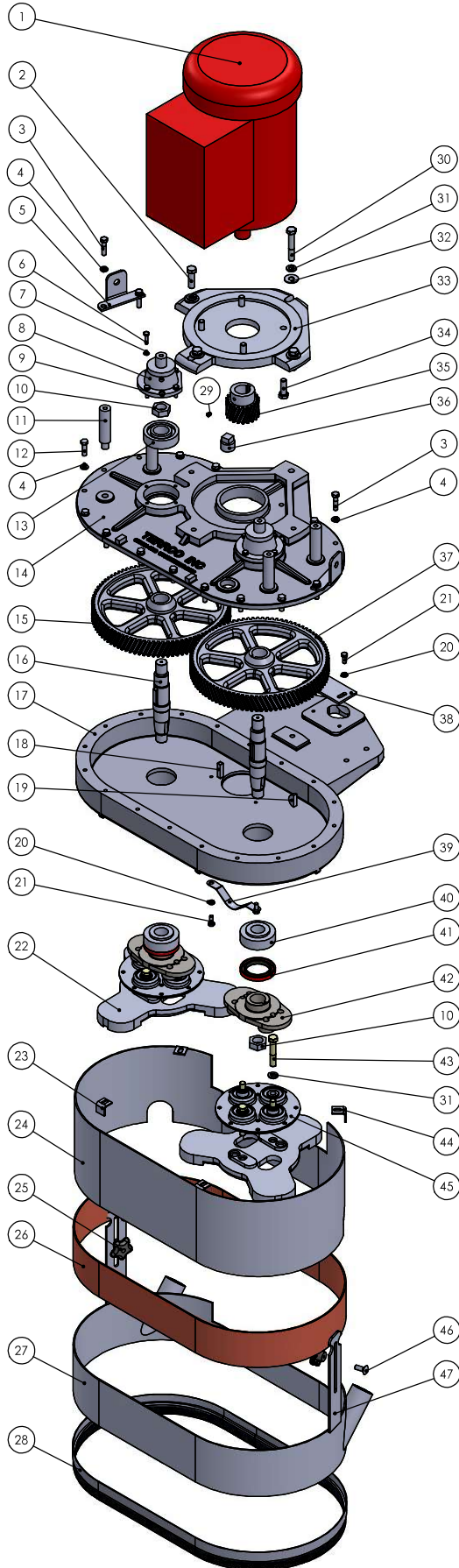

ITEM NO.	PART NUMBER	DESCRIPTION	QTY.
1	SM 349	7.5 HP, 1 PH, 230 V, 60 Hz MOTOR	1
	SM 349A	7.5 HP, 3 PH, 240/415 V, 50 Hz	
	SM 349B	7.5 HP, 3 PH, 230 V, 60 Hz	
	SM 349C	7.5 HP, 1 PH, 230 V, 50 Hz	
	LW 055	5 HP, 1 PH, 220 V, 50Hz	
2	T2006	1/2-13 X 1-3/4 LG HEX HEAD CAPSCREW	3
3	T2004	3/8-16 X 1-1/2 LG HEX HEAD CAPSCREW	8
4	T1022	3/8 MEDIUM LOCKWASHER	16
5	SM 535	GUARD BRACKET	2
6	T2018	CAPSCREW	8
7	T1030	LOCK WASHER, 1/4"	8
8	LW 023	BEARING CAP - R	1
	LW 023A	BEARING CAP - L	1
9	000170	GREASE FITTING 1/8" NPT STRAIGHT	2
10	T 2008	HEX HEAD NUT 1/4-20	4
11	SM 482	RISER PIN	4
12	T1025	3/8-16 X 1-1/4 LG HEX HEAD CAPSCREW	8
13	SM 043, SM 037	UPPER BEARING CONE & CUP	2
14	LW 002	GEAR CASE COVER	1
15	FE 004B	DRIVEN GEAR - R	1
16	SM 016	HELICAL GEAR SHAFT	2
17	LW 001	GEAR CASE	1
18	SM 072	HELICAL GEAR KEY	2
19	T2012	WOODRUFF KEY	2
20	T1007	LOCK WASHER	4
21	T2130	5/16-18 X 3/4" LG HEX HEAD CAPSCREW	4
22	SM 491A	SPEED SHIFT PLATE	2
23	SM 028	DRIVING SPIDER GUARD BRACKET	2
24	SMN 35	STATIONARY SPLASH GUARD	1
	SMN 35 - SS	STATIONARY SPLASH GUARD - STAINLESS STEEL	1
25	SM 537	HAND KNOB	2
26	SM 456	RUBBER DUST SEAL,01-S	1
27	SM 442	ADJUSTABLE DRY GUARD	1
	SM 335 - SS	ADJUSTABLE DRY GUARD - STAINLESS STEEL	1
28	LW 78(01-S)	BRUSH STRIP	1
29	T2057	SOCKET HEAD SET SCREW 5/16-18 X 3/8	1
30	T2021	HEX HEAD CAPSCREW 1/2-13 X 3" LG	1
31	T1012	1/2" LOCK WASHER MEDIUM	12
32	T2149	7/16 WROUGHT FLAT WASHER	4
33	SM 263	MOUNTING PLATE	1
34	T1009	1/2-13 X 1-1/2 LG HEX HEAD CAPSCREW	4
35	SM 214	PINION, 7.5HP	1
	LW 028	PINION, 5HP	
36	T2011	1" SW PLUG PIPE SCREW	1
37	SM 015L	DRIVEN GEAR - L	1
38	SM 328A	CARRIAGE PLATE	1
39	SM 172	HOSE CLAMP	1
40	SM 036, SM 037	LOWER BEARING CONE & CUP	2
41	SM 169	GEAR SHAFT GREASE SEAL	2
42	SM 500	DRIVING SPIDER	2
43	SM 171	MORFLEX COUPLING BOLT, ADV. J27B	8
44	SM 028L	LONG GUARD BRACKET	2
45	SM 088	COUPLING	2
46	T2029	CARRIAGE BOLT 3/8-16 X 1" LG	2
47	SM 536	GUARD STRAP	2



01-S PARTS LIST (HANDLEBAR ASSEMBLY)

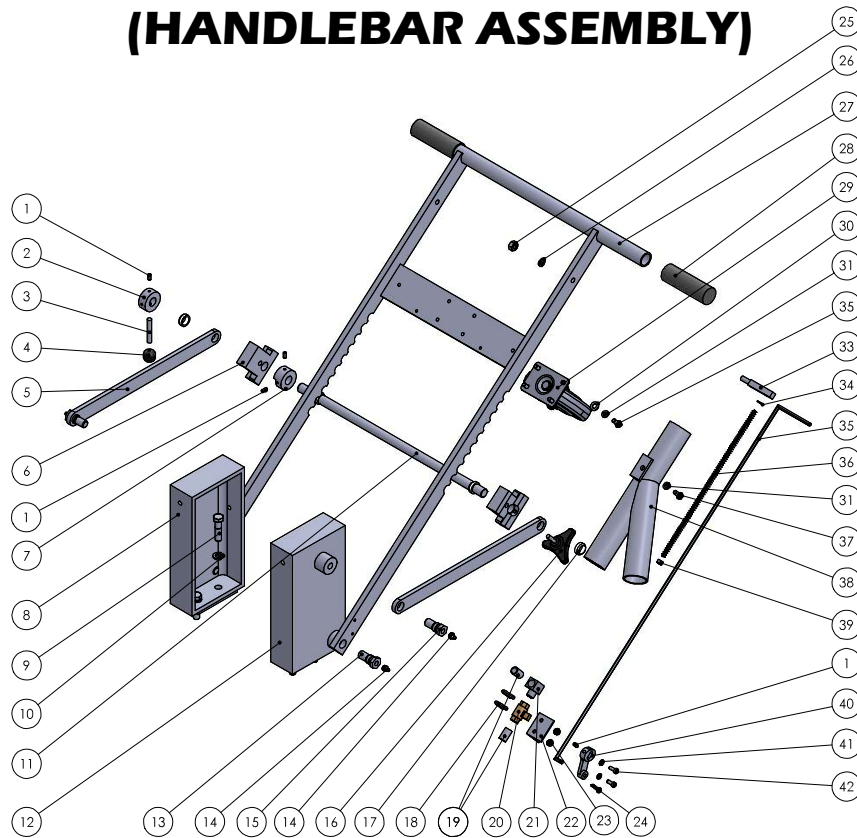

ITEM NO.	PART NUMBER	DESCRIPTION	QTY.
1	T3007	1/4-20 X 1/2 LG SOCKET SET SCREW	4
2	LW 032	COLLAR	1
3	LW 031	STUD	1
4	LW 033	PLASTIC KNOB	1
5	LW 015	STOP SIDE BAR	2
6	LW 009	HANDLE SLIDE BLOCK	2
7	LW 014	INDEXING STOP	1
8	LW 061	HANDLE BRACKET - R	1
9	T1024	CAPSCREW	4
10	T1012	1/2" LOCK WASHER MEDIUM	4
11	LW 070	POSITIONING ROD	1
12	LW 006	HANDLE BRACKET - L	1
13	LW 027	SHOULDER SCREW	2
14	000170	GREASE FITTING 1/8" NPT STRAIGHT	4
15	HBS 145	SHOULDER SCREW	2
16	HBS 196	5/16-18 KNOB	1
17	LW 024	STOP COLLAR	4
18	LW 011	WATER VALVE CLAMP	2
19	SM 175	VALVE STEM	2
20	SM 174	WATER TANK VALVE	1
21	LW 042	STREET ELL	1
22	LW 012	MOUNTING CLAMP	1
23	T2003	HEX HEAD NUT 1/4-20	14
24	T2082	COTTER PIN 3/32 X 1	1
25	T1026	3/8-16 HEX NUT, FULL	1
26	T1022	3/8 MEDIUM LOCKWASHER	1
27	LWN 001	HANDLEBAR ASSEMBLY (01-S)	1
28	SM 057	HANDLE GRIP	2
29	HB 088A	CASTER WHEEL	1
30	T2148	FLAT WASHER	4
31	T1007	LOCK WASHER	5
32	T3056	5/16-18 X5/8 LG SOCKET HEAD CAPSCREW	4
33	LW 029	HANDLE GUIDE	1
34	T2054	1/4" SAE FLAT WASHER	9
35	LW 018	WATER TANK HANDLE	1
36	SM 182	HANDLE SPRING, COMPRESSION	1
37	T2130	5/16-18 X 3/4" LG HEX HEAD CAPSCREW	1
38	SM 457	2" Y SECTION - DRY	1
39	SM 186	HANDLE SPACER COLLAR	1
40	LW 010	WATER TANK LEVER	1
41	T1030	LOCK WASHER	2
42	AH 017	1/4-20 X 5/8 LG FILLISTER HEAD	2



01-S PARTS LIST (HANDLEBAR CONTINUED)

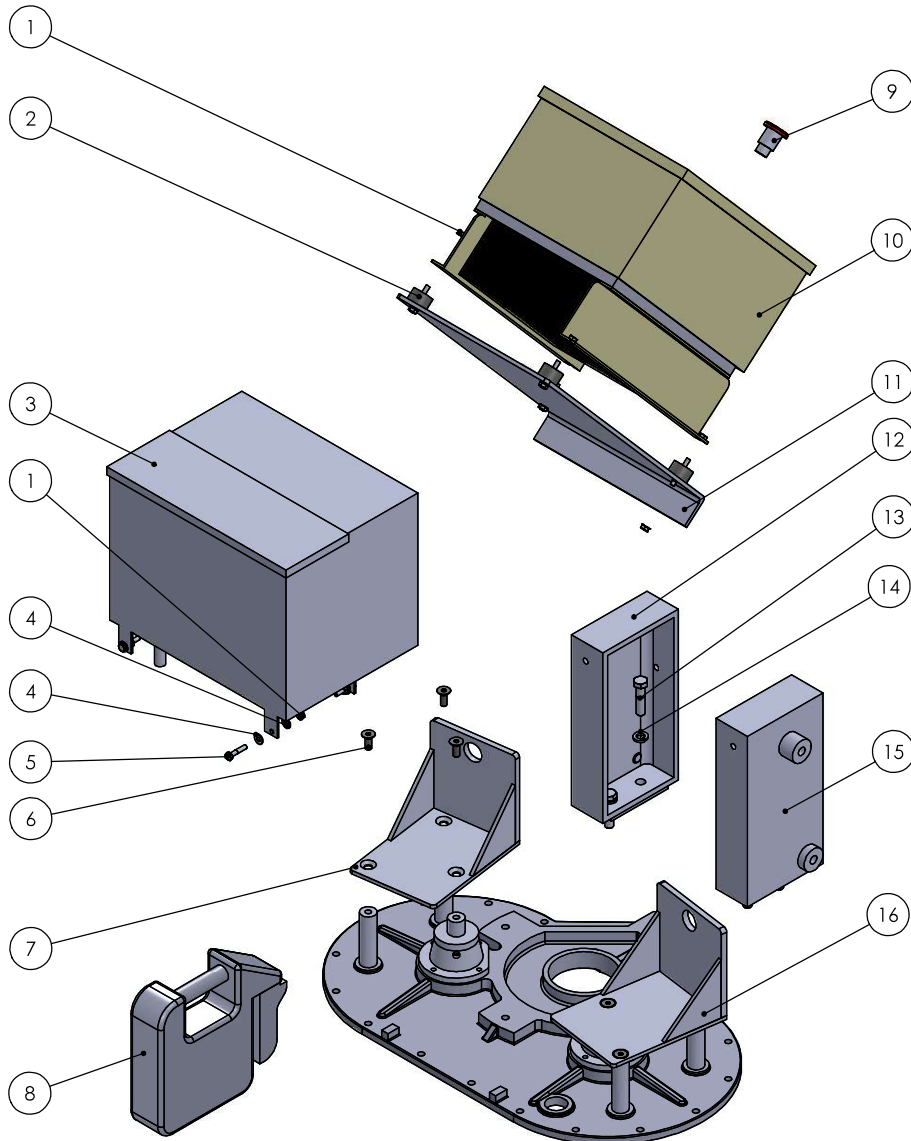

ITEM NO.	PART NUMBER	DESCRIPTION	QTY.
1	T2003	HEX HEAD NUT 1/4-20	14
2	FE 251	VIBRATION MOUNT	4
3	LW 008	WATER TANK	1
4	T2054	1/4" SAE FLAT WASHER	9
5	T2014	1/4-20 X 1-1/4 LG HEX HEAD CAPSCREW	4
6	T2116	3/8-16 X 1" LG SOCKET FLAT HEAD	6
7	FE 248L	UPPER WEIGHT HOLDER - L	1
8	FE 246	POCKET WEIGHT	4
9	LW 076	EMERGENCY STOP SWITCH ASSY	1
10	FE 490	YASKAWA 230 VOLT, 40 AMP, 15/7.5 HP	1
11	SM 497A	SWITCHBOX PLATE,BENT STEEL,01-S	1
12	LW 061	HANDLE BRACKET - R	1
13	T1024	CAPSCREW	4
14	T1012	1/2" LOCK WASHER MEDIUM	4
15	LW 006	HANDLE BRACKET - L	1
16	FE 248R	UPPER WEIGHT HOLDER - R	1



01-S PARTS LIST (SUSPENSION ASSEMBLY)

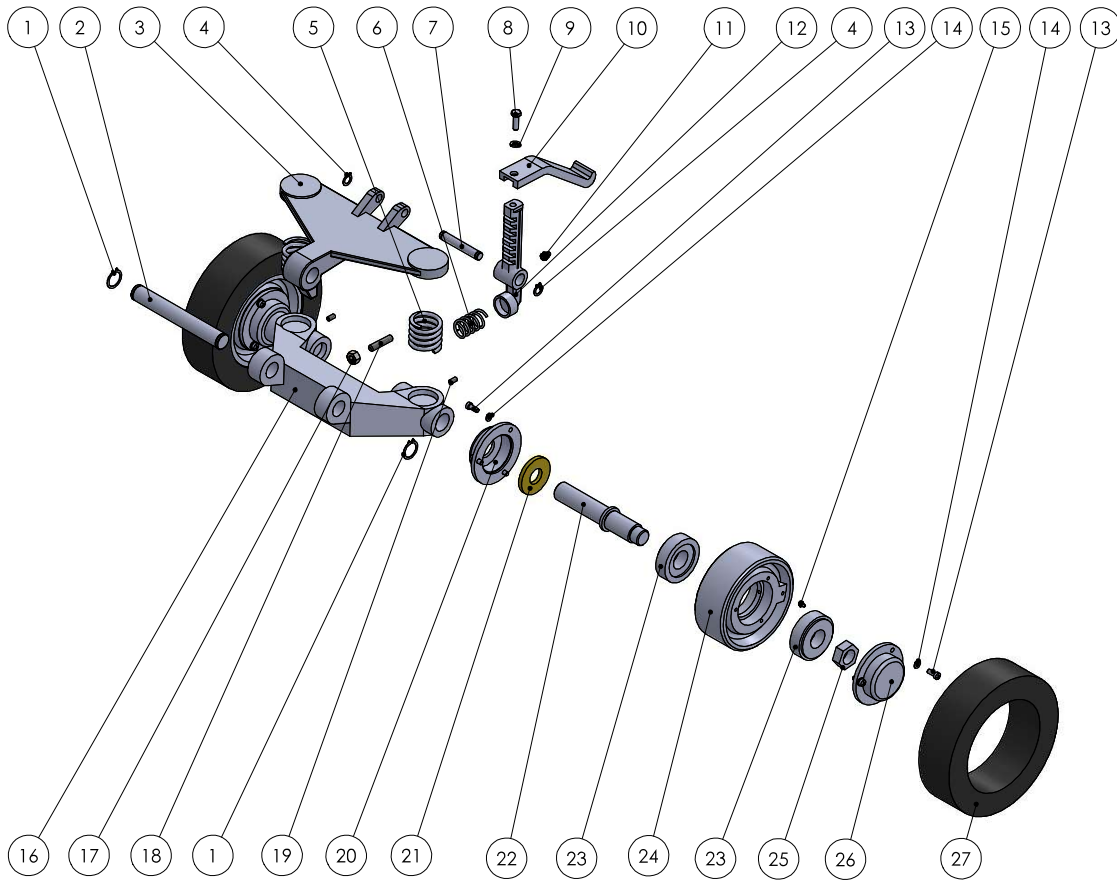

ITEM NO.	PART NUMBER	DESCRIPTION	QTY.
1	SM 331	SNAP RING	2
2	SM 327	PIN	1
3	SM 319	UPPER CARRIAGE BRACKET	1
4	SM 230	RETAINER RING	2
5	SM 326	SPRING	2
6	SM 325	SPRING	1
7	SM 329	PIN	1
8	T1006	5/16-18 X 1" LG HEX HEAD CAPSCREW	1
9	SM 255	7/16 BOLT SIZE SPLIT LOCK WASHER	1
10	SM 323	FOOT PEDAL	1
11	000170	GREASE FITTING 1/8" NPT STRAIGHT	1
12	SM 322	FOOT PEDAL ARM	1
13	AH 017	1/4-20 X 5/8 LG FILLISTER HEAD	12
14	T1030	LOCK WASHER, 1/4"	12
15	AH 026	GREASE FITTING 1/4-28 STRAIGHT	2
16	SM 320	LOWER CARRIAGE BRACKET	1
17	T1026	3/8-16 HEX NUT, FULL	1
18	T1055	3/8-16 X 1-3/4 LG SOCKET SET SCREW	1
19	T2026	3/8-16 X 1-2 LG SOCKET SET SCREW	2
20	SM 009	INNER BEARING CAP	2
21	SM 012	FELT WASHER	2
22	SM 011	WHEEL SHAFT	2
23	SM 069, SM 070	BEARING CONE & CUP	4
24	SM 008	WHEEL HUB	2
25	T2008	LOCK NUT	2
26	SM 010	OUTER BEARING CAP	2
27	SM 068	TRUCK WHEEL TIRE	2



WARRANTY CLAIM PROCEDURE



Each new machine is covered by two separate, distinct warranties: one on the machine and one on the electric motor or gasoline engine. Read **VERY CAREFULLY** the Terrco® warranty covering the machine, as this will tell you whether you have a warranty claim or not. If your machine is under warranty and malfunctions, determine whether your problem is electrical or mechanical, and do the following:

ELECTRICAL

1. Consult the list of authorized motor repair stations sent with the machine and locate the station nearest you.
2. Contact the repair station, giving them the following information:
 - Complete nameplate date from the motor.
 - Tell them that the machine is a terrazzo grinding and polishing machine.
 - Give them a description or rundown of the trouble.
 - Inform them of the voltage and amperage readings as outlined on page 2 of this manual.

MECHANICAL

1. Contact your Terrco® Distributor giving them the following:
 - Model and date purchased.
 - Horsepower.
 - Accurate description of the malfunction.
2. If there is no Terrco® Distributor in your area call or write to us with the above information.



LIMITED ONE YEAR WARRANTY



TERRCO® Inc. warrants the original purchaser of the Terrco® grinding equipment to be free from defects in materials and workmanship under normal use and service. Our obligation under this warranty shall be limited to the repair or exchange of any part or parts which may prove defective under normal use and service within one year from date of purchase by, the original purchaser, and which our examination shall disclose to our satisfaction to be defective.

All equipment returned for repairs or exchange must be returned to: TERRCO®, Inc., at the purchaser's expense and within the warranty period. All repaired or exchanged equipment will be shipped back to the purchaser F.O.B. Watertown, South Dakota.

THIS WARRANTY IS EXPRESSLY IN LIEU OF ALL OTHER WARRANTIES EXPRESSED OR IMPLIED INCLUDING THE WARRANTIES OF MERCHANTABILITY AND FITNESS FOR USE AND ALL OTHER OBLIGATIONS OR LIABILITIES ON THE PART OF TERRCO®, INC. AND WE NEITHER ASSUME OR AUTHORIZE ANY OTHER PERSON TO ASSUME FOR US, ANY OTHER LIABILITY IN CONNECTION WITH THE SALE OF THIS EQUIPMENT. SOME STATES DO NOT ALLOW THE EXCLUSIONS OR LIMITATIONS ON IMPLIED WARRANTIES OR DO NOT ALLOW THE EXCLUSION OF LIMITATION OF INCIDENTAL OR CONSEQUENTIAL DAMAGES, SO THE ABOVE EXCLUSIONS OR LIMITATIONS MAY NOT APPLY TO YOU. THIS WARRANTY SHALL NOT APPLY TO ANY EQUIPMENT OR PART THEREOF WHICH HAS BEEN SUBJECT TO ACCIDENT, NEGLIGENCE, ALTERATIONS, ABUSE, MISUSE, OR IMPROPER MAINTENANCE. TERRCO®, INC. MAKES NO WARRANTIES WHATSOEVER IN RESPECT TO ACCESSORIES OR PARTS NOT MANUFACTURED OR SUPPLIED BY US.